



THE MAHARASHTRA INSECTICIDES LIMITED

(Incorporated under Companies Act. 1956)

A Subsidiary of the Maharashtra Agro-Industries Development Corporation Limited.
Krushi Udyog Bhavan, Aarey Milk Colony Compound, Goregaon (E), Mumbai-400065

Email ID- milakola1@gmail.com ; pesticidesmaidc65@gmail.com

Website: www.maidcmumbai.com, Tel.: 29272068 / 2927066

E-tender Notice F.Y. 2026-27

E-tender for Procurement of

Pet Bottle (PM-81)

Closing Date 30/04/2026

PROCESSING FEES

Rs. 500/-

(In word. Rs. Five Hundred Only) shall be paid online only.

E-TENDER DOCUMENT FEES:

Rs 10,400/-

(In Word. Rs. Ten Thousand Four Hundred only) shall be paid on web portal online only.

E-TENDER EMD FEES:

Rs 1,00,400/-

(In Word. Rs. One Lakhs Four Hundred only) shall be paid online only.



THE MAHARASHTRA INSECTICIDES LIMITED

A Subsidiary of the Maharashtra Agro-Industries Development Corporation Limited
Krushi Udyog Bhavan, Aarey Milk Colony Compound, Goregaon (E), Mumbai 65,
Email Id : milakola1@gmail.com ; pesticidesmaidc65@gmail.com
Website: www.maidcmumbai.com, Tel.: 29272068 / 29272066

INDEX

Sr. No.	Particular	Annexure	Pages No
1	Tender Details	A	3-4
2	Specification for Pet Bottles	B	5-6
3	Diagram for Pet Bottle with Aluminium foil Seal for liquid Pesticides	C	7-10
4	Tender Schedule	D	11
5	Eligibility Criteria & List of Documents Required in Technical Bid	E	12
6	Format of Company Information	F	13
7	Format of Validity and Authentication Documents	G	14
8	Declaration for Non-Blacklisting	H	15
9	Format For C.A. Certified Turnover	I	16
10	Format For Signing Authority on The Bidder's Letter Head	J	17
11	Draft Agreement	K	18-19
12	General Terms & Conditions	L	20-33
		Total No of Pages -	33



THE MAHARASHTRA INSECTICIDES LIMITED

A Subsidiary of the Maharashtra Agro-Industries Development Corporation Limited
Krushi Udyog Bhavan, Aarey Milk Colony Compound, Goregaon (E), Mumbai 65,

Email Id : milakola1@gmail.com ; pesticidesmaidc65@gmail.com

Website: www.maidcmumbai.com, Tel.: 29272068 / 29272066

ANNEXURE - A

TENDER DETAILS

Product Name	Pet Bottles with Caps & Aluminium Foil Seal (Wad) Suitable for induction sealing		
**Estimated Quantity	Particular	Packing Size	Qty (Nos)
	Pet Bottles (Milky White)	100 ml	100000
		250 ml	500000
		500 ml	300000
		1 ltr	160000
		5 ltr	10000
(The **Estimated quantity is indicative and may vary based on actual demand and prevailing market conditions. Supply shall commence only against Dispatch Instructions (DI) issued by the C.E. MIL, from time to time and the quantity shall follow the DI.)			
Period of Supply	April 2026 to March 2027 (The period of the E-tender may be further extended for a further mutually agreed period, if any.)		
Specifications	As per enclosed Annexure-B		
Rate	Rate shall be submitted all-inclusive Free on Road (FOR) delivered destination basis (i.e., inclusive of freight & insurance) with detail bifurcation such as basic rate, discount on basic rate, GST etc. on 45 Days payment term basis		
Destinations	The Maharashtra Insecticide Limited Manufacturing Unit at Akola, Dist. Akola, Maharashtra State. 444104		
Payment Term	45 days credit		
Delivery Schedule	After placement of purchase order (PO) as per actual requirement through delivery instructions (DI) issued by the C.E. MIL, from time to time.		

E-tenders are invited from Qualified Manufactures/Traders/Importers on following major terms & conditions in addition to the general terms & conditions enclosed herewith. The **Estimated Quantity is mentioned above, but the Maharashtra Insecticide Limited reserves the right to increase or decrease the quantities without assigning any reason thereof. The Maharashtra Insecticide Limited reserves right to negotiate the rates after opening of the tender. The Maharashtra Insecticide Limited, reserves right to accept any tender in part or whole or to reject all tenders without assigning any reason thereof.

This E-tender Procurement procedure is being worked out as per Govt. of Maharashtra Procurement GR भांखस-2014/प्र.क्र.82/भाग-III/उद्योग-4 dtd 01/12/2016.

As per Govt. Circular No. भांखस-2018/प्र.क्र.125/उद्योग-4 dtd 06/01/2020, the procurement committee is empowered to amend, alter, relax or restrict any of the Terms & Conditions mentioned in the tender document, including technical qualification criteria, commercial offers and/or distribution/splitting of quantity of procurement among eligible bidders, as per prevailing conditions to ensure uninterrupted and continuous supply without any break at any stage of the supply contract.

1) Instruction to Bidder:

- a) The successful bidder quoted with L-1 Rates, does not mean that it shall be entrusted for entire supply quantity, instead it shall be evaluated for ability to supply the required quantity during the period of contract. The management reserves rights to evaluate the successful bidder's ability of supply on the basis of past performance, capacity to supply etc., and decide to issue the purchase order to the such bidder and not the entire quantity of supply to the L-1 bidder.
- b) Any additional forms or document other than specified in E-tender needs to be mentioned clearly on covering letter and clarification or references for fulfilling criteria for technical qualification shall be proved by the bidder only.
- c) The successful bidder required to sign an agreement for supply contract for the period mentioned above at the discretion of the MIL/Company.
- d) The detailed E-tender and other information can be access on www.maidcmumbai.com and www.mahatenders.gov.in Web-portal. Corrigendum / Amendments, if any, shall be published on above web-portal. No further notification for corrigendum/amendment shall be published in the newspapers separately.
- e) **Market Uncertainly Assessment and Timely Supply:** In view of any market uncertainty, bidders are advised to thoroughly assess material availability and timely supply prior to bidding, as the quoted rates shall remain firm and fixed for the entire contract period. No requests for price escalation, mid-term revisions, or excuses regarding non-availability of materials shall be entertained by the MIL under any circumstances. Violation of this term shall attract appropriate action including but not limited to risk cost purchases, forfeiture of security deposit, restrictions in participation of any tenders published by MIL from time to time, blacking of bidder for the period as decided by MIL and legal action as MIL may think suitable.



THE MAHARASHTRA INSECTICIDES LIMITED

A Subsidiary of the Maharashtra Agro-Industries Development Corporation Limited
Krushi Udyog Bhavan, Aarey Milk Colony Compound, Goregaon (E), Mumbai 65,
Email Id : milakola1@gmail.com ; pesticidesmaidc65@gmail.com
Website: www.maidcmumbai.com, Tel.: 29272068 / 29272066

ANNEXURE - B

NOT TRANSFERABLE

SPECIFICATION FOR PET BOTTLES WITH ALLUMINIUM FOIL SEAL (Wad) FOR LIQUID PESTICIDES. (Suitable for Induction sealing)

- 1) The bottles should be manufactured out of vergine PET material confirming to BIS Specification No. IS : 13193 for pesticides grade. The Intensive Viscosity of PET should be 0.80.
- 2) Bottles should be in milky white/coloured with white/coloured HDPE cap. The body of bottles should have corrugations & No of corrugations should be suitable as per body height of the bottles. The body thickness of the bottles should be uniform. Supply observed with deviated specification will be rejected.
- 3) Bottle's upper surface of mouth should be uniform, horizontal and suitable for Auto Induction sealing machine (without pressure). Supplies observed with uneven mouth surface will be strictly rejected. This is the cream of the specification. The dimensions & design of mouth of all sizes of bottles should be uniform so that same cap can be used for bottle of any capacity.
- 4) The bottles shall be in clean condition, the inside being free from all traces of dust and foreign matters. The bottles should be packed in sturdy corrugated boxes to form uniform standard packing. If the supplies are not as per the packing mentioned, the supplies are likely to be rejected. The bottles should not get de-shaped while handling & storage.
- 5) The dimensions & capacity of Bottles are as under :

<u>Capacity</u>	<u>Outer Diameter</u>	<u>Height mm</u>	<u>Weight of bottle without caps</u>	<u>Weight of Cap without wad</u>	<u>Total Capacity for Water</u>
100 ml	53 mm	96 mm	23 ± 1 gm	9.0 ± 1 gms	121.951 ml
250 ml	65 mm	130 mm	30 ± 1 gm	9.0 ± 1 gms	268.473 ml
500 ml	76.5 mm	170 mm	35 ± 1 gm	9.0 ± 1 gms	552.364 ml
1000 ml	95 mm	222 mm	65 ± 1 gm	9.0 ± 1 gms	1146.222 ml
5000 ml	170 mm	310 mm	174 ± 2 gm	9.0 ± 1 gms	5850.000 ml

Mouth Hight: - 32 mm (For All Packings)

Mouth Inner Diameter: - 38.50 mm

(All Dimensions are in mm).

- 6) The Brim-full capacity should be as per IS: 13123-2000.
- 7) Sample should be approved by us before actual supply. Drawing of the bottles from 250ml. to 1000 ml. is enclosed.
- 8) In addition to above, bottles should satisfy BIS Specification No. IS: 13123-2000.
- 9) The size of cap should be such that same size of cap should be suitable for all sizes of Pet bottles (46 mm nominal size, IS: 8393). Caps should be supplied with suitable wads with aluminium foils (Of Meyr, Germany) for induction sealing. The inner dimensions of cap & wads along with Aluminium foils should be such that the Aluminium foil can be properly sealed on induction heat-sealing machine (without pressure). The aluminium foil should not get damaged on un-screwing the cap after induction heat sealing. The caps should be supplied with wads properly fitted inside the caps. The quantity of caps should be + 5% of the bottle quantity.
- 10) Caps supplied should bear the MAIDC Logo embossed on the upper surface of caps.
- 11) The caps supplied along with suitable wads & Aluminium foil should fix easily on the neck of the bottles so that cap tightening can easily be done on screw on capping machine. The threads on neck of bottles & inside the cap should be such that the screwing & unscrewing of the cap on bottle neck (after fixing plug) can be done easily. The cap should not slip over threads of neck on full tightening. Also, the cap should not break/crack after fixing on filled bottle neck.
- 12) The bottle should be marked with manufacturer's name/recognized trade mark. In addition, the sign as per clause 7.1.1 of IS: 13123-2000 should be embossed on side of the bottle.
- 13) Bottle's wall thickness should not be less than 0.25 mm when measured with calliper gauge at any point of the wall.
- 14) Leap thickness of mouth should be minimum 2 mm.
- 15) Quality of Wad should be of Highest standards.

NOTE: -

- 1 The quantity of caps should be 5% more than the quantity of the bottles supplied.
- 2 The bottles supplied without caps will be treated as non-supply. Also, if the supplied caps are found non suitable for the supplied bottles, the same will be treated as non-supply.
- 3 Bottles should not get de-shaped nor vertically cracked after filling of pesticides. The quality of the bottles will be the total responsibility of the manufacturer. Any de-shaping/cracking of the bottles if noticed, will be liable for penalty/rejection of bottles.

Drawings for Pet Bottle with Aluminium foil Seal for liquid Pesticides.

A) 250 ml Bottle

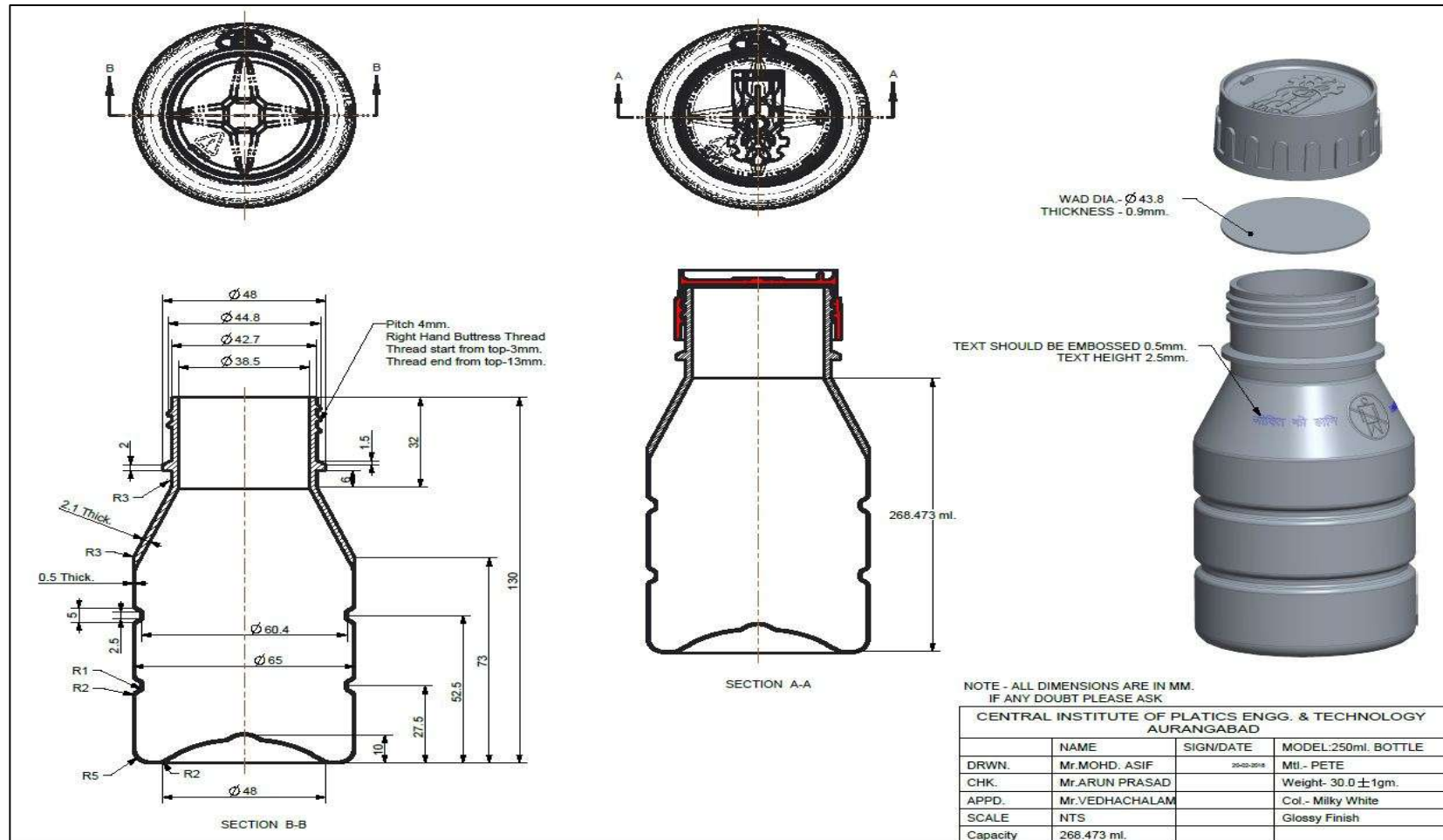

B) 500 ml Bottle

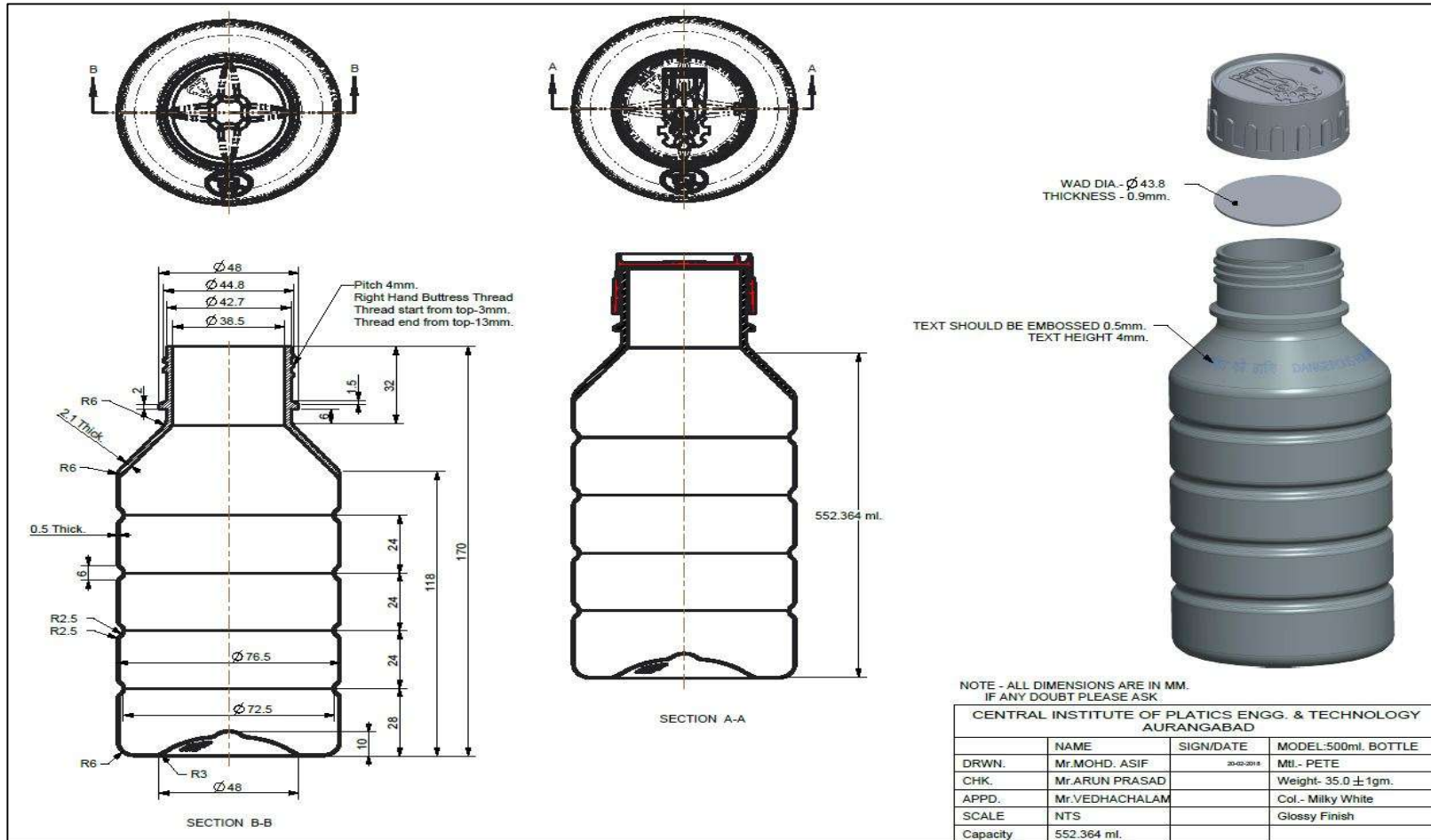

C) 1000 ml (1 Ltr) Bottle

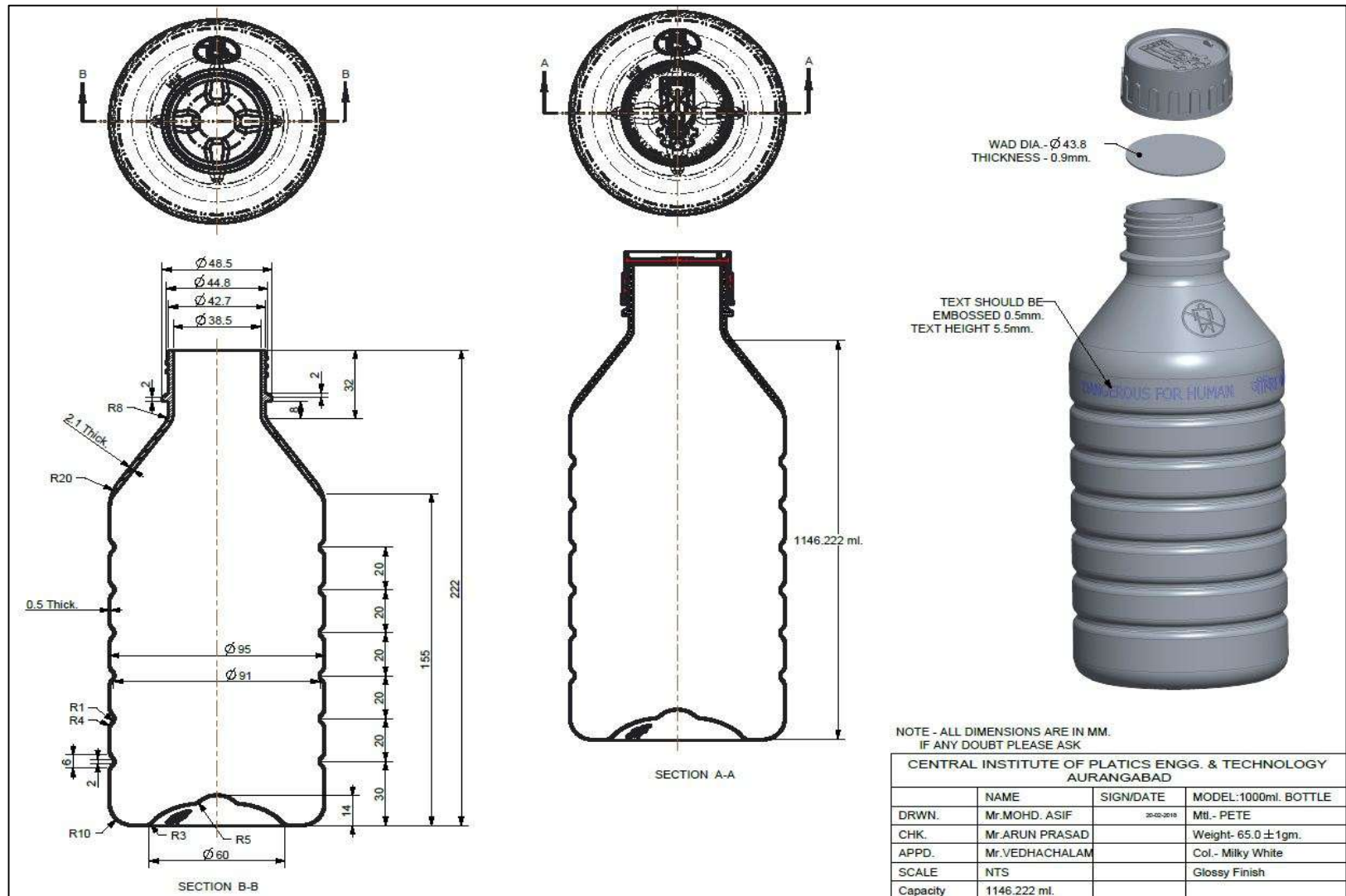

CAP FOR PET BOTTLES

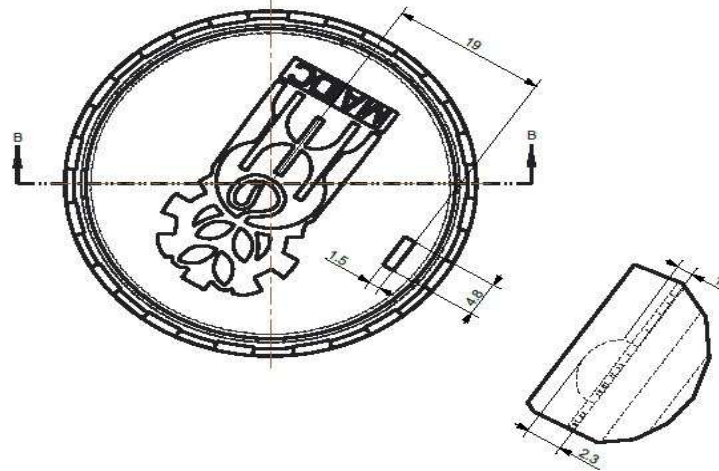

LOGO SHOULD BE EMBOSSED 0.5mm.

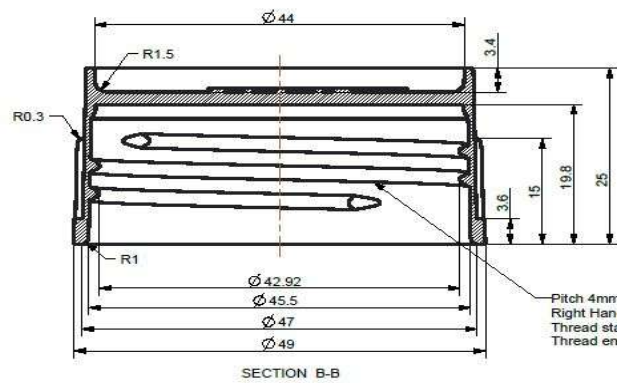

Pitch 4mm.
Right Hand Thread
Thread start from bottom-5.8mm.
Thread end from bottom-14.8mm.

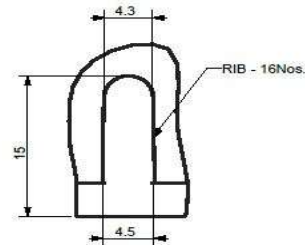

NOTE - ALL DIMENSIONS ARE IN MM.
IF ANY DOUBT PLEASE ASK

CENTRAL INSTITUTE OF PLASTICS ENGG. & TECHNOLOGY
AURANGABAD

	NAME	SIGN/DATE	MODEL: CAP
DRWN.	Mr. MOHD. ASIF	25-03-2016	Mtl. - HDPE
CHK.	Mr. ARUN PRASAD		Weight- 9.0 ± 1gms.
APPD.	Mr. VEDHACHALAM		Col. - Milky White
SCALE	NTS		Glossy Finish



THE MAHARASHTRA INSECTICIDES LIMITED

A Subsidiary of the Maharashtra Agro-Industries Development Corporation Limited
Krushi Udyog Bhavan, Aarey Milk Colony Compound, Goregaon (E), Mumbai 65,
Email Id : milakola1@gmail.com ; pesticidesmaidc65@gmail.com
Website: www.maidcmumbai.com, Tel.: 29272068 / 29272066

ANNEXURE - D

TENDER SCHEDULE

(A) TENDER SCHEDULE:

Sr. No.	Stages of Bidding	Schedule Date	Schedule Time
1)	Tender Release Date	06/04/2026	-
2)	Pre-Bid Meeting Date	10/04/2026	11.00 AM
3)	Tender Closing Date	28/04/2026	18.00 PM
4)	Technical Bid Opening Date	30/04/2026	18.00 PM
5)	Financial Bid of the successful bidders may be opened on the date decided by the MIL which may be updated on E-tendering web portal.		

Each stage may follow the date and time schedule mentioned against them. However, if the date and time Preponed / Postponed, may be published on www.mahatender.gov.in web-portal.

(B) Pre-Bid Queries

Name of the Bidder:					
Department Name: The Maharashtra Insecticide Ltd. (C/o The MAIDC Ltd.)					
Tender Ref No.:					
Tender Name:					
Due Date:					
Sr. No.	Bid Document Pg. no.	Bid Document Clause no.	Clause Title	Bidders Queries	Justification by MIL
1					
2					
3					
4					
5					

Note: Any Addendums/corrigendum (Amendment/Corrections) in the dates and tender notice shall be uploaded on the E-tendering Web Portal <https://mahatenders.gov.in>



THE MAHARASHTRA INSECTICIDES LIMITED

A Subsidiary of the Maharashtra Agro-Industries Development Corporation Limited
Krushi Udyog Bhavan, Aarey Milk Colony Compound, Goregaon (E), Mumbai 65,
Email Id : milakola1@gmail.com ; pesticidesmaidc65@gmail.com
Website: www.maidcmumbai.com, Tel.: 29272068 / 29272066

ANNEXURE – E

ELIGIBILITY CRITERIA & LIST OF DOCUMENTS REQUIRED IN TECHNICAL BID:

Sr. No.	Particulars	Self-Attested Copy Enclosures	Page No.
1	Receipt Of E-Tender Document Fees Rs. 10,400/-	Yes/No	
2	Receipt Of EMD Rs. 1,00,400/- As Applicable	Yes/No	
3	MSME / SME Certificate For E-tender Document Fees & EMD Exemption.	Yes/No	
4	List of Organizations / Company to Which Tendered Products Have Been Supplied.	Yes/No	
5	GST Registration Certificate.	Yes/No	
6	Format Of Company Information, Annexure-F (As Per Attached In E-tender)	Yes/No	
7	Undertaking For Validity and Authentication of Document, Annexure-G (As Per Attached In E-tender)	Yes/No	
8	Declaration For Non-Blacklisting by Any Govt./Govt. Institutes, Annexure-H (As Per Attached In E-tender)	Yes/No	
9	Format Of Average Annual Turnover of The Company for Last Three Years Shall Be More Than Rs. 25 Lakh (Rs. Twenty-five Lakh), Annexure-I (As Per Attached In E-tender, Format Should Be Certified by CA With UDIN No.)	Yes/No	
10	Format Of Signing Authority / Board Resolution / Letter of Appointing Authorized Signatory on Behalf of Bidder / Company. Annexure-J (As Per Attached In E-tender)	Yes/No	
11	Acceptance Of Draft Agreement Annexure-K (As per Attached in E-tender)	Yes/No	
12	Acceptance Of E-Tender General Terms & Conditions, Annexure-L (As Per Attached in E-tender)	Yes/No	

Chief Executive (MIL)

ANNEXURE – F

** To be printed on Bidder's Letter Head

COMPANY INFORMATION

1.	Name of the Company:	
2.	Registered Office Address:	
3.	Address For Correspondence:	
4.	Name of the Authorized Signatory:	
5.	Designation of the Authorized Signatory:	
6.	Mobile No. of The Authorized Signatory:	
7.	Name of the Other Contact Person:	
8.	Designation of the Contact Person:	
9.	Mobile No of The Contact Person:	
10.	Land Line Nos of The Company:	
11.	Fax Nos of the Company:	
12.	E-Mail Address of The Company:	
13.	GST No.:	
14.	PAN No. Of The Company:	
15.	Bank Details of The Company for Payments By RTGS	
a)	Beneficiary Name:	
b)	Credit Account No.:	
c)	Centre (Location):	
d)	Bank Name:	
e)	Branch Address:	
f)	Account Type:	
g)	IFSC Code:	

Also please enclose a cancelled cheque of above account for our ready reference.

Name & Designation of:
Authorized signatory

Authorized Signature of
Bidder with seal. & Date

ANNEXURE – G

**** To be printed on Bidder's Letter Head**

VALIDITY AND AUTHENTICATION OF DOCUMENT

I/We ----- (Name of company & its authorized sign) ----- undertake all the legal and statutory responsibilities for the validity and authentication of the documents submitted in the said tender/bid. That at any stage of tendering/bidding, if it is found that the documents/any part of the document objected by the MIL authorities/Other Bid participants/Govt. authorities/Public, I/We shall be responsible to prove the authentication of document/any portion of documents submitted with tender/bid. Further, I/We undertake that if documents/any portion of document proved legally invalid or not authenticated by concerned authorities, for this I/We shall be liable for any action and penalties therein by the MIL/company or appropriate legal action either by MIL/Company or concern Govt. authorities. That we have understood and satisfy myself/ ourself for entire terms & conditions of the tender/bid to participate in the same.

Sign and seal of company

Place :

Date :

Designation :

Name of Company
Authorized signatory :

Address :

**Note: - This undertaking shall be attached and submitted in tender docs in
Technical Bid-A otherwise bid shall be disqualified.**

ANNEXURE – H

**** To be printed on Bidder's Letter Head**

DECLARATION FOR NON-BLACKLISTING

I/We M/S _____ hereby declare that neither I/ We nor our Start-up or a parent, subsidiary or associate Company under direct or indirect common parent is/ are presently nor in the past been placed on any Black list / Debar/ Penalized by any Public Sector Company in India or by any Department of State or Central Government and that there is no pending inquiry by any Public Sector Company in India or by any department of State or Central Government, against us or a parent, subsidiary or associate Company as aforesaid in India, in respect of criminal, corrupt or fraudulent practice(s), is NIL.

It is understood that if this Declaration is found to be fraudulent, MIL shall have right to reject my/our offer, and if the offer has resulted in an investment, the investment agreement is liable to be terminated without prejudice to any other right or remedy (including Black list / Debar / Penalized) available to MIL.

Place:

Date:

**Seal & Signature of the Bidder or
Authorized Representative**

Note: This declaration shall be furnished on Bidder's "Letter Head"

ANNEXURE – I

**** To be printed on Bidder’s Letter Head**

FORMAT FOR C.A. CERTIFIED TURNOVER

I/We, have verified the books of accounts and other relevant records of M/s.

_____ Based on my verification and as per the information and explanation given to me/us, I/we Certify financial turnover of M/s _____ as under: -

Financial Year	Turnover In Rs. Lakhs
Financial Year 2023-24	
Financial Year 2024-25	
Financial Year 2025-26 (Tentative/Non-Audit)	
Total	
Annual Average Turnover of Last Three Years	

For Chartered Accountant
Seal & Signature

Place : _____

UDIN No.

Date : _____

ANNEXURE - J

FORMAT FOR SIGNING AUTHORITY ON THE BIDDER'S LETTER HEAD

To,
The Chief Executive,
Maharashtra Insecticide Limited,
Plot no. C-4, MIDC Area
Shivani Akola - 444104

Subject: Regarding Signing Authority.

I/We _____ undersigned, in the capacity of Proprietor /
Partner/ Board of Directors of the firm M/s. _____ having
office at _____
hereby authorise our employee / Represented named Shri _____
holding the post of _____ to sign in the E-tender and related document on
behalf of the firm.

Signing Person of the document

Name:

Designation and Seal:

Attesting and Authority:

Proprietor / Partner / Board of Director.

Name:

Designation and Seal:

Seal of the Firm

ANNEXURE - K

DRAFT AGREEMENT

(THIS AGREEMENT TO BE FURNISHED AFTER ACCEPTED
BID ON RON JUDICIAL STAMP Rs. 500/-)
(FOR SUCCESSFUL BIDDER ONLY)

This agreement made at Mumbai this day of..... , between The Maharashtra Insecticide Limited (MIL), having registered office at Plot No. 4, Shivani Akola 400104 hereinafter referred to as 'MIL' which expression shall unless repugnant to the context or meaning thereof include its successors, administrators and assigns of the First part.

AND

M/s. _____ having its registered office at _____
_____ acting through its _____ (hereinafter referred to as the seller which expression unless repugnant to the context and meaning thereof includes its assigns, successors and administrators of the Second part.

WHEREAS the MIL invited E-tender for Procurement of Various types of Technical Material, Bulk Material, Raw Material and Packing Material on the terms and conditions envisaged in the terms schedule issued with the E-tender Document and purchased by the seller.

AND WHEREAS the seller has accepted each and every term and condition contained in the E-tender Document, while submitting its bid. The seller has agreed to supply of quality materials on consignment basis on the terms and conditions of this agreement to the Maharashtra Insecticides Limited (MIL).

AND WHEREAS the Maharashtra Insecticides Limited (MIL) accepted the bid submitted by the seller vide its letter of acceptance no. _____ dated _____ in consideration of the mutual premises and undertakings hereinafter specified and for other good and valuable consideration this agreement witness and is hereby agreed on the conditions of the tender and the following documents shall form and be construed as the part of Agreement Deed:

:: 02 ::

- a) Specific and General terms & conditions of the tender Document
- b) Specifications of material
- c) The letter of acceptance dated _____
- d) The tender submitted by the supplier.
- e) The rates mentioned in annexure to agreement.

The aforesaid documents shall be taken as complementary and mutually explanatory of one another but in case of discrepancies and ambiguities shall take precedence in the order set out above, in this regard, the decision of Maharashtra Insecticides Limited shall be final.

For Seller

For Maharashtra Insecticides Ltd
Akola

Signature with Office Seal

Chief Executive, MIL-Akola

Witness:

1.

2.



THE MAHARASHTRA INSECTICIDES LIMITED

A Subsidiary of the Maharashtra Agro-Industries Development Corporation Limited
Krushi Udyog Bhavan, Aarey Milk Colony Compound, Goregaon (E), Mumbai 65,
Email Id : milakola1@gmail.com ; pesticidesmaidc65@gmail.com
Tel.: 29272068 / 29272066

ANNEXURE - L

GENERAL TERMS AND CONDITIONS

1) Terms and conditions hereinafter shall be binding on the Bidder. These terms and conditions shall come into effect immediately after the Bidder submits its E-tender along with Earnest Money Deposit to **Maharashtra Insecticides Ltd.** at above office address.

2) Definition & Interpretation:

In this E-tender for the General and Special terms and conditions the words shall have the following meanings unless the context otherwise requires.

- a) “**Acceptance of E-Tender**” means the letter or memorandum communicating to the Bidder for acceptance of this E-tender and signing of the supply agreement if any.
- b) “**Contract**” means invitation to E-tender, instructions to Bidders, acceptance of E-tender, particulars and the general and special conditions specified, in the acceptance of E-tender that includes repeat orders which has been accepted or acted upon by the Bidder and signing of the supply agreement if any.
- c) “**Bidder**” means the person/firm/company with whom the contract is made and includes its legal heirs, executors, administrators or successors and permitted assigns, as the case may be.
- d) “**Buyer**” means any person who is authorized by the Executive Director, Maharashtra Insecticides Ltd. to deal with the Bidder.
- e) “**Seller**” means the bidder participated in this E-tender and eligible for supply.
- f) “**Executive Director**” means The Executive Director of the Maharashtra Insecticides Ltd.
- g) “**Officer**” means Chief Executive or any person who is authorized by the Executive Director of the Maharashtra Insecticides Ltd. to deal with the Bidder.
- h) “**Material**” means all items mentioned in the purchase order/memorandum communicating the acceptance of the E-tender and signing of the supply agreement if any.

3) Parties:

The parties to the contract are the Bidder seller and the Buyer, MIL.

4) Submission Of E-Tender Offer:

Bidders shall submit the Bid through e-tendering web portal “<https://mahatenders.gov.in>”

5) Shortfall of Documents:

In the event of any shortfall, discrepancy, or omission in the documents submitted by a bidder with respect to the technical requirements of the tender, the bidder shall be formally intimated by the Company/Authority through email or any other official electronic communication mode. Upon such intimation, the bidder shall be required to submit the pending or revised documents within the stipulated time frame as specified in the communication.

Failure to comply within the prescribed timeline may result in rejection of the bid at the sole discretion of the MIL. The decision of the MIL regarding acceptance or rejection of documents shall be final and binding on the bidder.

6) Authority Of Person Signing the Contract on Behalf of The Bidder:

- a) The Bidder shall disclose the nature, constitution and registration of the Bidding firm and the bid shall be signed by a person or persons duly authorized to do so by means of legally valid documents which or a duly certified copy of the same shall be enclosed with the Bid.

OR

- b) A person signing the Bid or any documents in respect of the contract on behalf of the Bidder without disclosing it's authority to do so shall be deemed to warrant that it has authority to bind on behalf of the Bidder.
- c) If it is discovered at any stage and time of this E-tender that the person who is signing had no authority to do so, the Executive Director / or Chief Executive an officer authorized by the Executive Director may, without prejudice to any other right to remedy of the Bidder, cancel/reject the contract in part or full and or purchase the material at the risk and cost of such a person and hold such person liable to the Buyer for all costs and damages arising from the cancellation of the contract, including any loss which the Buyer may sustain on account of such Bidder.

7) Allotment of Contract (AoC):

- a) Address of the Bidder and notice and communications of allotment of contract (AoC) shall be sent unless the Bidder has noticed the change by separate letter containing no other communication and sent by Registered Post acknowledgement to the Executive Director or to the authorized officer of the MIL.
- b) The Bidder shall be solely responsible for the consequences of an omission to notify a change of address in the manner aforesaid.
- c) Any communication and notice on behalf of the Buyer, in relation to the contract may be issued to the Bidder by the Maharashtra Insecticide Limited and all such communication and notices may be served on the Bidder either by Email or any other electronic communications or registered post or under certificate of posting or by ordinary post or by hand delivery at the option of such officer or the Executive Director.

8) Authority Of the Executive Director / Officer:

For all the purposes of the contract including arbitration proceeding therein, the Executive Director and/or Chief Executive the authorized officer shall be entitled to exercise all the rights and powers of the Buyer.

9) Bid Scrutiny:

a) The Buyer shall scrutinize all the E-tender offers received by it. The Bids shall be opened on the day and time fixed as per above schedule. The Bidder or its authorized representative shall be at liberty to remain present at the time of opening the Bids.

b) This E-tender Procurement procedure is being worked out as per Govt. of Maharashtra Procurement GR भांखस-२०१४/प्र.क्र.८२/भाग-III/उद्योग-४, दिनांक ०१ डिसेंबर २०१६.

As per Govt. Circular No भांखस-२०१८/प्र.क्र.१२५/उद्योग-४, दिनांक ०६ जानेवारी २०२०, the procurement committee is empowered to amend, alter, relax or restrict any of the terms & conditions mentioned in the tender document, Including technical qualification criteria, commercial offers and/or distribution/splitting of quantity of procurement among eligible bidders at any stage of the contract.

c) After scrutiny of the Bids, it shall be the right of the Buyer either to accept one or more Bids and/or to reject any one or all the Bids.

d) The Buyer shall not be bound to disclose any reason either for acceptance or rejection of Bid. **No correspondence / communication/ compensation/ claim in this respect from Bidders shall be entertained by the Maharashtra Insecticide Limited.**

10) Rejection OF BID: Any Bid,

a) Which varies from E-tender terms & conditions or stipulate counter conditions

OR

b) Which fails to provide required information or is otherwise incomplete.

OR

c) Which is received from the Bidder/its partner having implicit or explicit relations with the employee of the Buyer is liable to be rejected.

11) Acceptance OF BID:

The acceptance of Bid rest with the Buyer, which does not bind itself to accept the lowest Bid and reserves to itself the rights as below,

a) To reject any or all Bids,

b) To split the purchase order quantity amongst two or more Bidders. Buyer may split the purchase amongst eligible bidders at its sole discretion.

c) Buyer reserves the right to split the purchase order quantity in whole or in part without assigning any reason whatsoever.

d) Buyer does not have any guarantee/warrants any minimum quantity of supply during the tenure of the contract.

- e) To negotiate with one or more Bidders for revision of rates downwards if the Buyer is of view that the rates so received are not appropriate.
- f) Buyer reserves right to evaluate the rates offered by the Bidders by comparison from the market and renegotiate the rates so offered by the bidder at any stage or of period of the contract.
- g) To reject the Bid on the basis of unsatisfactory performance of the Bidder in pursuance of previous contract with the Buyer.
- h) To reject the Bid of delisted/ blacklisted Bidder by any other company/Govt. institution/ undertaking etc. due to unsatisfactory performance, forfeiture of EMD or any other reason.
- i) To reject the Bid having financial or business association with the Buyer's employee.
- j) When Bids are received from any proprietorship/firm/companies having the same proprietor or one or more partners/Directors in the business organization of any other party (hereinafter called common firms), such Bids shall be considered as having been received from only one applicant in different names and the lowest acceptable quotation of such common firm shall only be considered for evaluation.
- k) When Bids are received from any proprietorship/firms/companies having one or more common business facilities such as CIN No. telephone, email, brand, emblem, address etc. shall be considered as having been received from only one Bidder in different names and the lowest acceptable quotation of such common firm shall be considered.

12) Splitting of Bid Quantity: -

As per the past experience of Govt. Orders or Open Market supply for tendered product, the MIL may have to supply in large quantity in different packing, in limited time all over Maharashtra, in such case to manage demand and supply, the MIL may distribute/split quantities of supply over / amongst eligible participated Bidders to which bidder shall not have any legal or statutory objection.

13) Variation in Tender Quantity (As per 2016 GR)

In case of high demand, administrative exigencies, or upon completion of the originally awarded tender quantity, the Company/Authority reserves the right to increase the contract quantity by up to 50% of the originally approved/awarded quantity, in accordance with the provisions of the Government Resolution (GR) issued in 2016, as applicable from time to time.

Such increase shall be subject to mutual consent of both parties and shall be executed under the same terms, conditions, rates, specifications, and contractual provisions as stipulated in the original tender/contract, unless otherwise mutually agreed upon in writing.

The implementation of the additional quantity shall strictly comply with the guidelines and financial provisions laid down under the said 2016 Government Resolution and subsequent amendments, if any.

14) Assignment Of Subletting the Contract:

- a) The Seller shall not assign or sublet the contract or any part thereof or allow any person to become interested therein in any manner whatsoever without the previous consent in writing of the Buyer, which consent the Buyer shall be entitled to withhold without assigning any reason or ground thereof.
- b) Any breach of this term shall entitle the Buyer to take such steps as may be necessary and also terminate the contract.
- c) Such termination, shall also render the Seller liable for payment to the Buyer in respect of any loss or damage arising or ensuing from such cancellation.
- d) The permitted subletting of work by the Seller, shall not establish any contractual relationship between the sub-Seller and the Buyer and shall not release the Seller of any responsibility under the supply contract.
- e) In the event of sufficient dues not being available to compensate for the above, the Seller shall reimburse the Buyer for the same by making payment through a DEMAND DRAFT/NEFT/RTGS etc.

15) Earnest Money Deposit (EMD):

- a) The interested bidders shall have to make online payment (using net banking) at the time of online bid submission stage of the Bid schedule.
- b) That if the Bidder backs out after submission of Bid (within the validity period of the Bid) and on before or after acceptance of its Bid (either whole or in part) the Buyer shall have right to forfeit the amount of earnest money deposit.
- c) Amount of earnest money shall be refunded to the unsuccessful Bidders whose Bids are not accepted by the Buyer, in due course of time without any interest. In case of Bidders whose tenders and/or Bids are/is accepted by the Buyer, their amount of earnest money deposit shall remain with Buyer till the completion of contract, until satisfactory settlement of accounts and compliances of the terms of E-tender.
- d) The Bidders Registered under MSME i.e. small-scale industrial units or registered with Director of industries, Govt. of Maharashtra and submitting their Bids directly, shall pay or Exempt EMD as specified by Govt. of Maharashtra Procurement GR भांखस-2014/प्र.क्र.82/भाग-III/उद्योग-4 दिनांक 01/12/2016 and their amendment from time to time, they shall produce necessary proof / Certificate supporting that they belong to small scale industrial sector.

16) Security Deposit (SD):

- a) The successful bidders shall be required to pay an interest free Security Deposit.
- b) The Bidder whose Bid is accepted by the Buyer, shall deposit an amount of Security Deposit equivalent to 3% of the value of the material for which the supply order is placed by the Buyer.

- c) The successful bidder fails to submit security deposit, the same amount will be deducted from first and subsequent bills of supply to the extent of 3% of bill amount / Total Purchase amount, till the completion of entire Tender Qty. Purchases and satisfactory completion and compliance of the contract.
- d) Security Deposit deducted as above shall be valid for the period of one year or contract Period, it shall be refunded after due and satisfactory fulfilment / performance of the contract on the part of the Bidder.
- e) The Security Deposit (above mentioned) shall be retained by the Buyer during the period of contract till the satisfactory settlement of the accounts/ transactions arising out of the contract without any interest.
- f) If contract is fulfilled/ completed within the prescribed period and if the period for performance of the contract is extended by the Buyer, in that case Bidder shall have to extend the period of Security Deposit and/or furnish fresh Security deposit covering such extended contract during the extended period.
- g) If the Bidder fails or neglects to observe or perform any of its obligations under the Contract, it shall be lawful for the Buyer to forfeit either in whole or in part the Security Deposit deposited by the Bidder.
- h) If the Bidder duly perform and complete the contract in all respect and presents a certificate of satisfactory completion of contract issued by the "OFFICER", the Buyer shall refund the Security Deposit to the Bidder after deduction of all cost and other expenses that the Buyer may have incurred and all dues and other amounts including losses and damages which the Buyer is entitled to recover from the Bidder in reasonable time.

17) Validity Of Bid:

The rates offered by the Bidder shall be valid for acceptance for minimum of 90 days from the date of opening of the Bid.

18) Market Uncertainly Assessment and Timely Supply:

In view of any market uncertainty, bidders are advised to thoroughly assess material availability and timely supply prior to bidding, as the quoted rates shall remain firm and fixed for the entire contract period. No requests for price escalation, mid-term revisions, or excuses regarding non-availability of materials shall be entertained by the MIL under any circumstances. Violation of this term shall attract appropriate action including but not limited to risk cost purchases, forfeiture of security deposit, restrictions in participation of any tenders published by MIL from time to time, blacking of bidder for the period as decided by MIL and legal action as MIL may think suitable.

19) Rates:

- a) The rates specified in the Bid shall be exclusive of GST (GST may be mentioned separately) but inclusive of transport, any other insurance, taxes, toll, duties of any kind, cess, levies, royalty or commission in respect of the supply. Any other taxes, duties, levies by whatever name called imposed and leviable on the material sold in pursuance of this contract shall be borne by the-Bidder.

- b) No rate revision shall be considered during the period of contract. However, any increase/decrease in the statutory Levis may be considered on producing the concerned notification & proof of payment or any other related documents required by the Maharashtra Insecticide Limited.
- c) However, the variation in the statutory duties on account of business turnover/status shall not be considered.
- d) The Bidder shall quote all-inclusive the FOR rates in given (BOQ) format online only and addressed to the
The Maharashtra Insecticides Ltd (MIL)
Plot No. C-4, MIDC Industrial Area,
Shivani, Akola, Maharashtra.
Pin code - 444104.
- e) **Invoice-** The Bidder shall submit commercial tax Invoice in triplicate indicating tax separately to the Maharashtra Insecticide Ltd., Akola.
Mentioning GST NO **27AABCM8932B1ZM.**
- f) The Bid quantity once accepted and purchase order placed with the Bidder by the Buyer, the bidder shall be bound to supply the same.
- g) The Bidder shall offer only such quantity, which may be in position to supply during the contract period.
- h) **Acceptance of Rates:** Counter offers shall be considered by the MIL only to those bidders whose offer rates are within the limit of L-1 + 15% only

20) Parallel Rate Contract:

The Maharashtra Insecticides Ltd reserves the right (a) to enter into parallel rate contract(s) simultaneously or at any time during the period of the rate contract with more Bidders as MIL may think fit, and (b) to place ad-hoc contract or contracts simultaneously at any time during the period of this contract with more seller(s)/ Bidder(s) for such quantity and such item as the competent authority of MIL (whose decision shall be final) may determine.

21) Termination Of Contract and Black List of Supplier: MIL may terminate Contract or Black list seller(s) in the following event of default:

- a) Breach of any of the terms or conditions or obligation of Contract on part of Seller / his employees / agents.
- b) Any major material alteration in the specifications (if any) of the product to be supplied without the authorization of MIL and / or competent authority or non- supply or delay in supply beyond 15-20 days as stipulated in P.O. / Delivery Instructions.
- c) Any major material alteration in the agreed specification (if any) of the product to be supplied without the authorization of MIL and / or competent authority.

- d) MIL at its discretion may call for any record to satisfy themselves regarding supply of material to its units. The seller shall provide every help/ document related to MIL, failing which it may amount to breach of condition of the contract.
- e) The Seller being adjudged bankrupt/insolvent or a trustee/ receiver being appointed on the Supplier.
- f) Repudiation of agreement by seller or otherwise evidence of intention not to be bound by the agreement.
- g) fails to supply goods within delivery schedule,
- h) fails to perform contractual obligations,
- i) supplies sub-standard goods,
- j) becomes insolvent, or
- k) Engages in corrupt or fraudulent practices.

Upon such termination, Security Deposit shall be forfeited, Buyer may procure goods at risk & cost of Supplier, Extra expenditure shall be recoverable, and seller may be debarred / blacklisted from future procurement or tenders published by MIL from time to time.

22) Penalty / Liquidated Damages for Delayed Supply

Delay in Delivery - If the seller fails to deliver goods within the stipulated delivery period 15-20 days. The buyer shall recover Liquidated Damages (LD) at the rate of: 0.5% per week (or part thereof) of delayed supply value Maximum ceiling: 10% of contract value.

23) Integrity & Confidentiality

- a. All technical, commercial, financial, operational or proprietary information exchanged between the parties shall be treated as confidential.
- b. The seller shall not disclose such information to any third party without prior written approval of the Buyer.
- c. The obligation shall survive expiry or termination of the contract.
- d. Any breach of confidentiality shall be treated as material breach and may result in termination of contract and recovery of damages.

24) Negotiations:

It is clarified that normally the MIL may make negotiation on the rates and therefore the Bidders shall quote their lowest prices only. However, the Executive Director of the MIL may decide to give counter rate of the lowest rate as decided by it.

25) Payment Of Supply: -

- a) Unless otherwise agreed upon by the Buyer, payment of the value of the material supplied by the bidder in good condition and as per specification & composition of Buyer's requirement, hence tested & certified sample of material at the Maharashtra Insecticide Ltd., Akola shall be considered & accepted by the Buyer and accordingly payment shall be released by Maharashtra Insecticides Ltd., Akola within **45 days from**

the date of receipt of material at factory and satisfactory fulfilment of quality specifications and test reports thereon.

- b) Security Deposit amount may be refunded to the successful bidder only after satisfactory, completion of contract with respects to tender term and by providing GST paid confirmation certificate duly certified by a Chartered Accountant.

26) Risk & Cost Purchases:

- a) The submission of online Bid along with the Terms & Conditions duly signed and sealed by the Bidder shall be deemed as acceptance of the Terms & Conditions by the Bidder.
- b) Once the rates offered by the Bidder are accepted by the Buyer and that if the Bidder backs out after submission of Bid and/or acceptance of Bid, the Buyer shall have right to purchase the material on the risk & cost of the Bidder.
- c) Bidder shall be liable to pay losses or damages or costs incurred by the **Maharashtra Insecticides Ltd.**, in such transactions.
- d) Buyer reserves the right to blacklist Seller in future participation in the Bids or any other tenders published by the Buyer, in case of non-supply of indented quantity and or substandard quality and dimension of specifications of supply.

27) Taxes:

- a) The Bidder shall indicate in detail the taxes applicable, (percentage of applicable taxes may please be mentioned in the Bid) the requirement of submission of various forms under the GST Act.
- b) The bidder shall also quote GST registration number on its tax invoice.
- c) All invoices shall have noted tax elements separately e.g., Basic rate + GST OR any taxes, etc. No inclusive rates shall be quoted.

28) Packing & Forwarding:

The packing & forwarding charges shall be borne by the Bidder only.

29) Insurance:

- a) Whenever rates accepted all inclusive, FOR delivery of the material, the Bidder shall be fully responsible for the breakages/damages and/or losses of the material during the transit.
- b) Insurance charges for the material shall be borne by the Bidder.

30) Delivery & Delivery Schedule:

Bidder shall deliver the material at the addresses mentioned above by the Buyer.

- a) The Buyer after placing final purchase order shall issue the delivery instructions, indicating dates, quantity, and type of material to be delivered as per requirement from time to time.
- b) The Bidder shall be bound to effect the deliveries strictly in according with dates, time and specifications and other instructions mentioned on indents therein.

- c) The Buyer shall have right to make alternations / modifications in the delivery schedule from time to time and as per requirement.
- d) That if the Bidder, fails to deliver the material or any part thereof within the period fixed for such a delivery, the Buyer shall, without prejudice to the right of the Buyer, recover damages, losses, costs for breach of terms of contract at Buyer's sole discretion.

31) Weighments/ Sampling:

- a. Weighments, quantity & quality assessment of material certified by Buyer's factory shall be final, irrespective of the quantities dispatched & lab test report submitted by the Bidder, issued by any laboratories.
- b. Rejected quantities shall not be considered for acceptance on any ground or any reasons whatsoever by the bidder.
- c. Contract shall be declared fulfilled, if the quantity delivered is 5% more or less than the quantity contracted in a purchase order. Buyer may allow such variation at its own discretion.
- d. The goods shall be inspected at Buyer's option either at Buyer's factory or at Bidder's factory before dispatches or deliveries.
- e. The M.I. Ltd, reserves the right to appoint an inspection Agency for reshipment during the period of a contract.
- f. The inspection charges for respective inspection agency shall have to be borne by the Bidder only.
- g. Random samples shall be drawn by the Maharashtra Insecticide Limited for the goods delivered at the Maharashtra Insecticide Limited factory, in the presence of the Bidder or representative of Seller if, remains present at the time of delivery at the Maharashtra Insecticide Limited factory.
 - i. If Bidder willing to remain present while drawing/sealing of samples at the Maharashtra Insecticide Limited factory site, the Maharashtra Insecticide Ltd., may wait in such case for 48 hours from the date/time of receipt of material, and shall draw the samples thereafter without any further period.
 - ii. Samples such drawn shall be final (i) Samples drawn shall be tested in the Maharashtra Insecticide Ltd., laboratory or laboratories approved by the Maharashtra Insecticide Ltd., or Govt. Laboratories and the results shall be communicated to the Seller/bidder within reasonable period from the date of receipt of material. (ii) In case of dispute regarding the quality of the material, joint sampling may be done in the presence of Seller's representative. Joint report may be accepted for all purpose. Seller shall send its representative for joint sampling and intimation by the Maharashtra Insecticide Ltd., from the date of receipt of test report, otherwise the MIL's report shall be considered as acceptable to Seller without any reason whatsoever.

32) Rejection Of Supplies:

- a) The material supplied if not conforming to the quality specifications and all other parameter it shall be rejected by the Maharashtra Insecticide Ltd., at its sole discretion.
- b) If any material is rejected by the Maharashtra Insecticide Ltd., then at its sole discretion shall exercise any one or more than one of the following.
 - 1) To permits the Bidder for replacing material of right specifications without any further cost to Maharashtra Insecticide Ltd., within specified time.

or
 - 2) Buy the entire supply consignment or part quantity of material rejected or any other material for similar purpose at the risk and cost of the Bidder without affecting Bidder's liability as regards supply of balance consignment, due under the period of contract.
 - 3) Consignment rejected as aforesaid, must be lifted by the Seller within 15 days from the date of communication of rejection by the Maharashtra Insecticide Ltd., against replacement of equal quantity, and such rejected material shall lie at the Bidder's risk and cost from the time of such rejection and if not lifted within the aforementioned time, the Maharashtra Insecticide Ltd., shall have the rights as below.
 - 3.1 Either to return the rejected material on freight to pay basis

or
 - 3.2 To dispose of such material at Bidder's risk and cost,

or
 - 3.3 To retain such portion of the material as may be necessary to recover any loss or additional expenses incurred by the MIL in reference with such sale or adjust the material against ones from the Seller/bidder.
 - 3.4 The rejected goods if not lifted by the Seller within 15 days from the date of intimation, shall incur storage charges per unit per day plus loading, unloading charges extra at applicable rates from time to time.
 - 3.5 The Maharashtra Insecticide Ltd., shall be at liberty to dispose off or to destroy the rejected goods, if not lifted within 15 days at the risk and cost of Bidder.
 - 3.6 If the supply is consistently of poor quality, the balance quantity of order shall be cancelled and the Bidder may be debarred/ or blacklisted from the participation of any future Bids of Maharashtra Insecticide Ltd., or any other tenders of the buyer.
 - 3.7 The rejected material if not replaced by Bidder within 15 days, the Maharashtra Insecticide Ltd., may at its sole discretion, can accept the material at the adjusted rate or with quality cut penalties within tolerable limits which the Maharashtra Insecticide Ltd., may think suitable.

3.8 It is sole discretionary right of the Buyer to blacklist the Bidder at any time, if material supplied fails to comply quality parameters/ specifications / norms / composition/ Standards, etc. at any stage of or any time of supply contract.

33) Withholding Of Lien in Respect of Sums Claimed:

- a) Whenever any claim or claims for payment of sum of amount arise out of or under the contract against the Bidder, the Buyer shall be entitled to withhold also for a lien to retain a sum or sums in whole or in part from the pending bills and 'Security Deposit' of the Bidder for the aforesaid purpose.
- b) The Buyer shall be entitled to withhold said pending bills and Security Deposit and also for a lien over the sum pending finalization or adjudication of any such claim.
- c) In the event of pending bills and Security Deposit being sufficient to cover the claim amount or amounts or if no pending bills and Security Deposit are there from the Bidder, Buyer shall be entitled to withhold and have a lien to retain to the extent of such a claim amount or from any sum of amount referred to be found payable or which at any time thereafter may become payable to the Bidder under this contract or any other contract with the Buyer.
- d) It is an agreed terms of the contract against the sum of amount or amounts so withheld or retired under the lien referred to above, by the Buyer, till the claim arising out of or under the contract is determined by the arbitrator or competent court as prescribed hereafter, the Bidder shall have no claim interest or damages whatsoever or any action in respect of such withholding or retention under the lien referred to and duly notified as such to the Bidder, for the purpose of this clause whether the Bidder is partnership firm or limited company, the Buyer shall be entitled to withhold and also have lien to retain towards such a claim amount or amounts in hold or in part from any sum found payable to any partner limited company as the case may be whether in individual capacity or otherwise.

34) Indemnity:

- a) The Bidder shall exclusively agrees that it shall indemnify and hold Buyer harmless at all times from and against all claims, demands, damages, costs, actions, suits and proceedings of whatsoever nature made, which Buyer may suffer or incur and which arise out of the Bidder's breach of any Terms & Conditions of this contract or breach of any representations or warranties made by the Bidder or any liability incurred or claimed against Buyer by any person whatsoever with regard to quality specifications, characteristics of the material supplied under this contract or for any breach or alleged breach or infringement of any Intellectual Property Rights (IPR) of the Buyer or of a third party howsoever and whatsoever or any other damage, cost etc. paid and any liability/damages/cost of expenses suffered by the Buyer directly or indirectly as a result of arising out of the foregoing or breach or no observance.

- b) Without prejudice to the above, it shall also be specifically agreed by the Bidder that it shall indemnify Buyer against any loss suffered by the Buyer on account of quality issues such as content deficiency, weight, moisture, water soluble contents etc. and all other liabilities including legal expenses arising out of non-confirmation of CIB/BIS specifications.

35) Laws Governing the Contract:

- a) This contract shall be governed by the laws of India for time being in force.
- b) Irrespective of the place of delivery, the performance or the place of payment under the contract, the contract shall be deemed to have been made at the place from which the acceptance of the Bid has been issued.

36) Jurisdiction Of the Courts:

The courts at Mumbai, Maharashtra shall alone have jurisdiction to decide any dispute arising out of or in respect of the contract.

37) The Executive Director/Chief Executive/Officer shall at any time by notice in writing similarly determine the contract without compensation to the Bidder in any of the following events i.e., to say:

- a) If the Bidder being an individual, or if a firm of any partner thereof, shall at any time, be adjudged insolvent or shall have a receiving order or ordered to administration of its state made against it or shall take any proceedings for composition under any insolvency or for the time being in force or make any conveyance or assignment of its effects or enter into arrangement or composition with its creditors or suspend payments or if the firm is solved under the partnership act.

OR

- b) If the Bidder being a company is wound up voluntarily or by the order of Bidder receiver, liquidator or manager or behalf of the debenture holder is appointed or circumstances shall have arisen which entitled the court or debenture holder to appoint receiver, liquidator or manager.
- c) If the Bidder commits any breach of the terms of the contract not herein specifically provided. For provided always that such determination shall not prejudice any right of action or remedy which shall have approved or shall approve thereafter to the Buyer and provided also the Bidder liable to any, the Buyer for any extra expenditure has thereby put and the Bidder shall under no circumstances be entitled to any gain on Buyer's purchase.

38) Arbitration:

- a) In the event of any dispute or differences arising out or relating to, under or in respect of this contract, the same shall be referred at the written request of either party to a sole arbitrator to be appointed by mutually approved arbitrator in accordance with the Arbitration and Conciliation Act, 1996 and the Rules, if any, made there under and any statutory modifications or re-enactment thereof.
- b) The venue of arbitration proceedings shall be at Mumbai

- c) Any arbitration award made in such arbitration proceedings shall be final and binding on both the parties.
- d) If at any point of proceeding, during or after the currency of the contract, it is found that the concerned bidder/Seller has tried/or approached any of the officials of the Maharashtra Insecticide Ltd., to influence outcome of the Bid, the Seller concerned shall be summarily debarred/blacklisted from any further dealings with the Maharashtra Insecticide Ltd.,

39) Force Majeure:

- a) The Bidder and the Buyer shall not be responsible for delay and/or breach of performance on account of force Majeure conditions if and to the extent caused by matters beyond the reasonable control of the parties but not limited to the acts of God, acts of Govt. authority, strikes, lockouts/lockdown, trade disputes or concerned acts of workmen lasting over fifteen (15) days, fires, floods, severe draughts, earthquake, explosion, riots, epidemic or pandemic or quarantine etc.
- b) However, the party affected by such force Majeure situation shall intimate the other party forthwith.
- c) In the event to supply the required quantity on account of workers issues or situation arising out of force majeure condition, intimation in writing given to Buyer by the Bidder, and on such intimation the liability to supply under this contract shall cease until such issues or circumstances prevailed.
- d) If workers issues persist for more than two (2) months and the Bidder is unable to fulfill its obligations, Buyer shall have option to terminate this contract by giving one month's written notice to this effect.

40) Special Instructions to Bidder:

- a) Any successful bidder is found to Defame corporation misleading statement or reasons or facts or attracts, negative publicity or damage brand image of the MIL, in such case the MIL, shall have right to debar such bidder for three years or permanently black list for participating in Any tender of the MIL, from time to time.
- b) Bidders shall not quote rate lower anywhere than rates quoted for the MIL, tender to any Govt. supply/Semi Govt./KVK's/Agril. Universities or any other such institutions.

We acknowledge that we have read and understand all the terms and conditions of the Bid with Sound, mind & health and hereby confirm that the same are accepted and binding on me/us.

Authorized Signature of Bidder with seal

Note: - The Bidder is requested to sign and place seal on each page before uploading the documents.